



BENSON

OUH

Oil Fired Unit Heaters



telephone
0116 288 4333

freephone
0808 108 7575

airability.co.uk



OUH

Oil Fired Unit Heaters

The Benson range of oil fired unit heaters is suitable for a wide variety of commercial and industrial applications.

OUHA units are fitted with a high capacity axial fan for optimum air distribution. The OUHA 60 - 100 models are fitted with twin fans.

OUHC models have centrifugal fans for ducted installations.

Optional Equipment

A range of options are available. These include:

- > Stainless steel heat exchanger
- > High/low burner on models 60 - 100
- > Combustion air adaptor
- > SmartCom SZ control complete with summer fan only facility
- > Two stage or modulating damper actuators
- > SmartCom MZ upgrade for two stage and modulating damper control
- > Vertical louvres, 30° & 90° downflow nozzles
- > Wall brackets
- > Mixing plenum box dampers and filters (OUHC only)

Model Range

The OUH Series oil fired heaters are available in six heat outputs ranging from 31kW to 103kW, for use on 35 sec oil with vertical flue spigot.

Alternatively, units may be specified for use with Kerosene (28 sec).

Specification

Heat Exchanger and Burner

The high efficiency heat exchanger is designed for both long operational life and to have minimal resistance to airflow through the unit.

Cabinets

Cabinets are constructed from electro zinc coated steel panels, finished in epoxy polyester powder coated paint.

Air Distribution

Powerful axial fans fitted on OUHA models provide optimum air distribution via horizontal outlet louvres.

OUHC units are designed for ducted applications and are fitted with centrifugal fans and a duct spigot outlet. A fan box plus optional dampers is also available on OUHC models.

Safety Controls

To ensure safe automatic operation, each unit is fitted as standard with comprehensive safety controls and flame monitoring. To prevent against insufficient airflow a limit thermostat is fitted which shuts down the heater in the event of overheating.

Features & Benefits

- > High thermal efficiency 89 - 91% (based on net calorific value) resulting in lower running costs
- > Space saving - all units can be either suspended or base mounted thereby freeing up floor space for production or storage requirements
- > Simple low installation costs
- > Riello burners bio-fuel compatible up to 10% blend

Applications

- > Factories
- > Horticulture
- > Warehouses
- > Workshops
- > Showrooms

Installation

Units may be suspended or alternatively mounted on a suitable non-combustible support. Four M10 suspension points are provided to each heater.

Each heater is supplied with a loose fire valve and oil filter. An additional oil fire valve should be installed external to the building where required in accordance with BS 5410:Part2:1978.

A single phase electrical supply is required to each unit. This supply should not be switched off except for maintenance.

An optional rear spigot connection can be provided when ducted combustion air to the burner is required.

Units must not be installed in atmospheres containing highly flammable or explosive vapours, combustible dust, halogenated hydrocarbons or chlorinated vapours. They are also unsuitable for areas where contaminants may affect electrical motors or connections.

Controls

A combined fan and limit switch is fitted on all heaters. In the event of overheating the unit would automatically be shut down by the limit thermostat.

All heaters are supplied with an electronic programmer complete with optimised control, this is factory fitted and wired on free-blowing vertical models. For horizontal, and all duct outlet models down flow heaters the controller is supplied loose for on site wiring by the installer.

		Model Ref					
		OUH 30	OUH 40	OUH 60	OUH 70	OUH 90	OUH 100
Nominal heat output	kW	31	40	59	72	88	103
Airflow	m ³ /h	3240	3672	5760	6840	8784	9468
Temperature rise	°C	29	32	30	31	30	32
Throw ¹ (OUHA)	m	21	23	31	37	36	39
External static pressure (OUHC)	Pa	150	150	180	150	180	180
Fuel Consumption							
Fuel consumption (35 sec)	l/h	3.5	4.5	6.5	8.0	9.7	11.6
Fuel connection	Rc	3/8"	3/8"	3/8"	3/8"	3/8"	3/8"
Electrics							
Supply	V/ph/hz	230/1/50	230/1/50	230/1/50	230/1/50	230/1/50	230/1/50
Electrics FLC (OUHA)	amps	1.6	1.6	2.8	2.8	3.4	3.4
Electrics FLC (OUHC)	amps	8.0	8.0	11.0	11.0	15.0	15.0
Recommended mounting height ²	m	2.0 - 3.2	2.0 - 4.0	2.4 - 5.0	2.4 - 4.5	2.4 - 5.0	2.4 - 5.0
Noise level ³	dB(A)	61	65	68	69	71	72
Net weight							
Axial (OUHA)	kg	116	116	177	177	240	240
Centrifugal (OUHC)	kg	138	138	212	212	280	280

1. Throw is dependent on mounting height, building height, room temperature and louvre settings.
2. Recommended height to underside of heater for standard horizontal discharge units. For buildings over 4 metres high, air re-circulation fans are recommended in conjunction with the heaters.
3. Noise levels measured at 3 metres from appliance for OUHA models

	Model					
	OUH 30	OUH 40	OUH 60	OUH 70	OUH 90	OUH 100
A (unit height)	780	780	780	780	980	980
B (unit width)	1050	1050	1475	1475	1750	1750
C (unit depth)	895	895	895	895	1025	1025
D (flue diameter)	125	125	150	150	175	175
E	755	755	1177	1177	1365	1365
F	17	17	17	17	17	17
G	640	640	640	640	770	770
H	20	20	20	20	20	20
J	36	36	36	36	36	36
K	183	183	170	170	231	231
L	340	340	340	340	405	405
M	1175	1246	1175	1175	1376	1376
N	212	212	212	212	300	300
P	139	139	139	139	219	219
R (duct outlet OUHC)	729	729	1151	1151	1339	1339
S (duct outlet OUHC)	730	730	730	730	930	930

OUHA Axial Fan

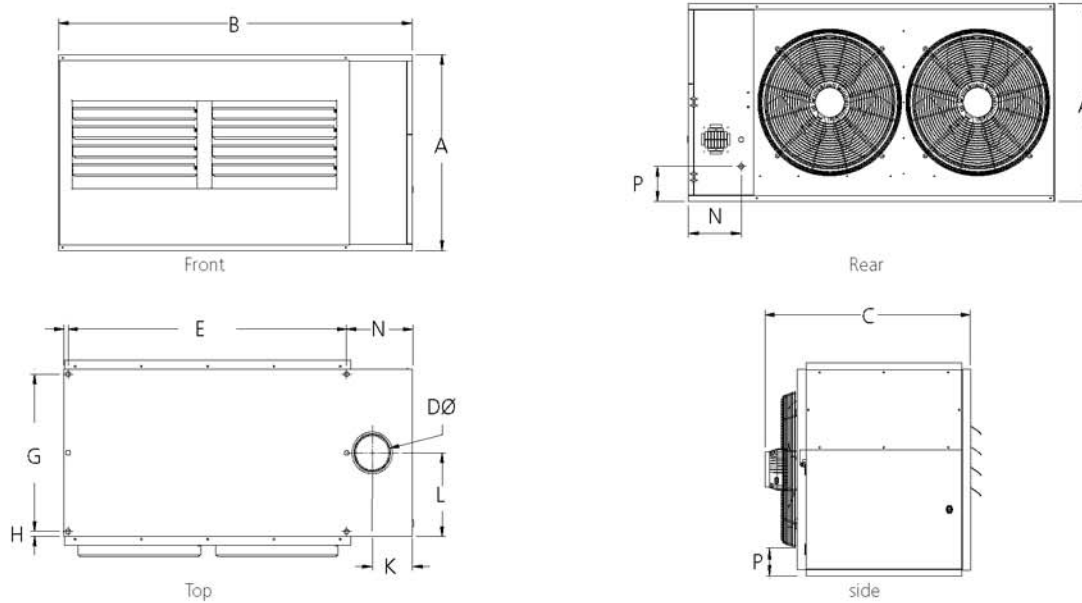

OUHC Centrifugal Fan

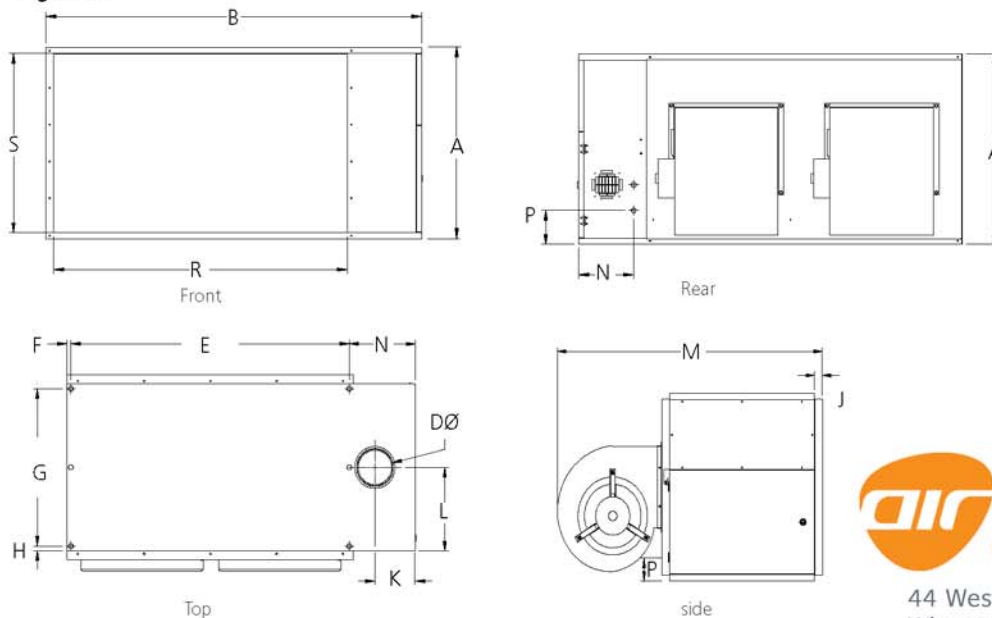

Document reference number: GB/BEN/005/0413



44 Westley Grange, West Avenue
Wigston, Leicestershire LE18 2FB

Tel: 0116 288 4333
Fax: 0116 288 1444

info@airability.co.uk
www.airability.co.uk

Air Ability Limited. Registered in England No. 6065045

